

BG Series AC Power Circular BarGraphs

Watt, VAR and Power Factor Meters for Single and Three Phase Systems

These Weschler BG Series Circular BarGraphs are optimized for AC power measurements. The ACP4 series BarGraphs utilize self contained Current Transformers (CT) and accurate solid state circuitry to measure both single and poly phase systems.

Weschler BarGraphs combine the visual indication of an analog meter with the precision of a digital instrument. Large digits and a wide viewing angle allow operators to easily monitor the signal from a distance. Four case sizes and three versions (standard, enhanced and tricolor) offer a broad choice of features and functions.

Weschler BarGraph Watt and Varmeters can replace analog instruments such as the Weschler/Westinghouse KP-241, KP-261, KV-241 and KV-261. The analog backplate option duplicates the Westinghouse terminal stud connections. The BG-241 and BG-261 panel footprint and mounting also match other 4½" and 8½" switchboard meters such as the GE AB40, DB40, AB16 and DB16. The BG-251 and BG-281 sizes match Ashcroft 6" and 8" gauges.

Weschler BarGraph instruments are housed in a rugged steel case. They are designed for long life in utility switchboards and other control applications.

FEATURES

- **Tri-color or single color bar**
- **High resolution digital display**
- **Signal Trend arrows**
- **Adjustable setpoints**
- **Form C relay outputs**
- **Peak and Valley hold**
- **Analog retransmit**
- **Rugged steel case**

The Weschler ACP4 Power Series BarGraph is a self-contained instrument. No external current transformers, voltage transformers or phase shifters are required to measure up to 240V and 10A. However correct installation is critical. Consult the phaser diagrams to determine the proper configuration and phase orientation for the application, particularly in retrofit situations. Note that some three phase analog VAR meters may have been specified as a Wattmeter with a VAR scaleplate and 90 degree phase shifter. The ACP4 only supports an external phase shifter in 4-wire systems. For VAR measurements in 3-wire systems, the external phase shifter must be bypassed.

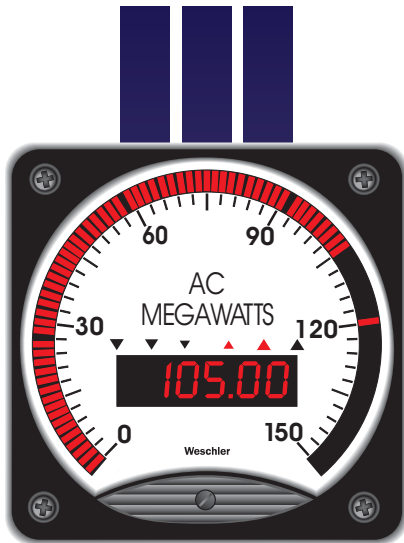

BG-261

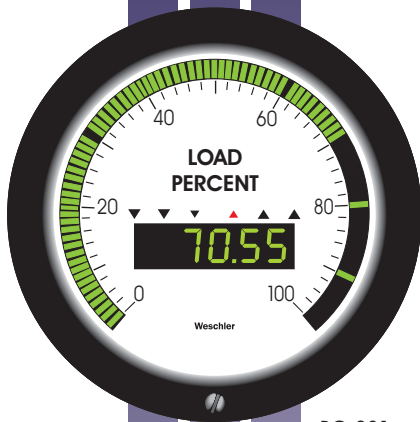

BG-281

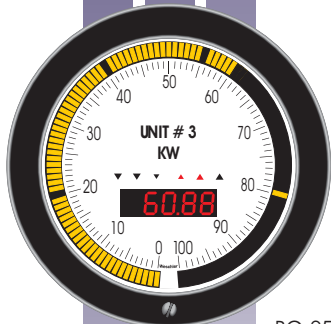

BG-251

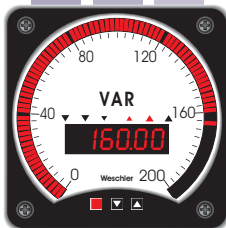

BG-241

FEATURES

Wattmeters and Varmeters

	Standard	Enhanced	TriColor
Measurement Range	± 19999	-9999 to 50000 (Neg Autoscale)	± 50000
Potential Range	120, 240 V rms	120, 240 V rms	120, 240 V rms
Self-Contained Current Maximum	10 A rms	10 A rms	10 A rms
Numeric Display Characters	4½ Digit	4¾ Digit	4¾ Digit
Numeric Display Color	Red	Red, Green or Amber	Red, Green or Amber
Bar Color	Red	Red, Green or Amber	TriColor
Bar Segments	101	101	50
Bar Resolution	1%	1%	2%
Display Brightness	Fixed	Two Level Programmable	16 Level Programmable
Alarm Hysteresis	0.5, 1 & 2% FS	0.0-10.0% FS	0.00-10.00% FS
Relays	2 or 4 Form C	2 or 4 Form C	2 or 4 Form C
Relay Latching Mode	N/A	Yes	Yes
Relay Fail-safe Mode	N/A	N/A	Yes
HI - LO Alarms	2 HI, 2 LO	Individually Programmable	Individually Programmable
Analog Retransmit	256 Step Resolution	65000 Step Resolution	65000 Step Resolution

SPECIFICATIONS

Inputs

Potential (Voltage)	
Nominal	120, 240 Vac
Maximum Continuous	150, 300 Vac
Momentary Overload	175, 325 Vac
Input Impedance	1MΩ
Current	
Nominal	10 A
Maximum Continuous	12.5 A
Momentary Overload	100 A for 500 ms
Input Impedance	Internal CT, 0.1Ω
Frequency	50/60 or 400 Hz
Response Time	1 sec.

Uncertainty

Display (W or VAR)	± 0.5% Full Scale, ± 1 count
Setpoints	± 0.1% Full Scale, ± 1 count
Temperature Coefficient	
Standard	± 1.3 ppm / °C
Enhanced & TriColor	± 0.5 ppm / °C

Bar Display

Scale Length	
BG-241	285°
BG-261/281	270°
BG-251	270°/345°

Digital Display

Resolution	
Standard	0.005%
Enhanced and TriColor	0.002%
Height	
BG-241	0.4" (10.16 mm)
BG-261/281	0.8" (20.32 mm)
BG-251	0.56" (14.22 mm)

Communications

RS-232	9600 baud, 1 start bit, 1 stop bit, no parity, no flow control
RS-485	Half duplex, 9600 baud, 1 start bit, 1 stop bit, no parity, no flow control
Protocol	
Standard & Enhanced	Party Line
TriColor	Motorola "S"

Setpoint Relays

Quantity	2 or 4
Contact Arrangement	SPDT (Form C)
Type	
Standard	2 HI (ascending trip) and 2 LO (descending trip)
Enhanced & TriColor	All programmable HI or LO
Contact Ratings	5A, 120/240 Vac or 30 Vdc resistive 1/14 HP 120/240 Vac inductive MOV clamp
Contact Protection	Selectable for all setpoints collectively
Hysteresis	

Analog Retransmit

Standard	256 step resolution, voltage source 0-1, 4-20, 10-50 ma; 0-5, 1-5 V
Enhanced & TriColor	65000 step resolution, current source 0-24 ma, 0-10 V programmable

Environment

Operating Temperature	-20 to 60°C (Standard) -20 to 50°C (Enhanced & TriColor)
Humidity	0- 95% non-condensing. Condensation allowed with conformal coating option.
Storage Temperature	-40 to 85°C

Meter Power

	Nominal	Tolerance	Current (Maximum)	
			Standard	Enhanced & TriColor
12 Vdc	10-15 V		225 ma	825 ma
24 Vdc	18-36 V		125 ma	420 ma
28 Vdc	18-36 V		100 ma	350 ma
48 Vdc	36-72 V		65 ma	210 ma
125 Vdc	± 10%		25 ma	75 ma
250 Vdc	± 10%		12 ma	25 ma
120 Vac	± 10%, 50/60 Hz		2.5 VA	12.5 VA
240 Vac	± 10%, 50/60 Hz		1.3 VA	12.3 VA

Fuse

Plug-in, rear panel accessible

Connections

BG Backplate	#6 screw terminals for AC signals; Phoenix plug in connectors for Relays, Analog Retransmit & Communications (mating connector supplied)
Analog Backplate	#10-32 studs for AC signals; Relays, Analog Retransmit and Communications not available

ORDERING GUIDE

PART NUMBER

Specify scale markings and legend when ordering

TYPE:

- 4 = BG-241 4½" Square BarGraph
- 6 = BG-261 8½" Square BarGraph
- 8 = BG-281 8" Circle BarGraph
- 3 = BG-251 6" Circle BarGraph*

*not available in TriColor

BAR ZERO POINT:

- B = Zero at Bottom
- H = Zero at 50% mid scale
- F = Zero at F.S.
- S = Special /off scale zero

DISPLAY:

- 4 = 4½ digit Standard
- E = 4¾ digit Enhanced
- T = 4¾ digit Tricolor

SETPOINTS:

- N = Hi/Lo
- H = Hi/Hi-Hi
- L = Lo/Lo-Lo
- 4 = Hi-Hi/Hi/Lo/Lo-Lo
- B = 2 relays, programmable Hi or Lo *
- D = 4 relays, programmable Hi or Lo *
- X = None
- S = Special order

*Enhanced or Tricolor only

SETPOINT HYSTERESIS:

- 1 = 1% of F.S.
- 2 = 2% of F.S.
- 5 = 0.5% of F.S.
- X = Not required
- S = Special.
- P = Programmable 0-10% or Latching *

*Enhanced or Tricolor only

INPUT TYPE:

- L = Watts single phase
- H = Watts three phase
- V = VARs single phase
- Z = VARs three phase
- Y = VARs three phase for external phase shifter (4-wire only)
- G = Power factor (display 1.00 max, specify lag on right or left)

Specify:

CT ratio _____ Full scale Watts value _____

PT ratio _____ External phase shifter _____

System Delta or WYE

DIGIT COLOR**:

- B = Red (Enhanced or Tricolor)
- X = Red (Standard)
- G = Green (Enhanced or Tricolor)
- A = Amber (Enhanced or Tricolor)
- M = Red with Multi-color bar *
- S = Special

*Enhanced only

- Y = Spraytight Face
- B = Analog Backplate
- K = Conformal Coating
- A = Custom Artwork
- X = NA

- T = Trend Indicator
- X = NA

- P = Peak/Valley Hold
- X = NA

COMMUNICATION:

- A = RS232
- C = RS485 Bi-directional
- X = None

RETRANSMIT:

- A = 4-20mA DC into 250Ω
- B = 0-1mA DC into 1000Ω
- C = 1-5V DC
- D = 0-1V DC
- F = 4-20mA DC (isolated)
- G = 0-1mA (isolated)
- T = 0-10V across 500Ω (isolated) *
- K = 0-1V across 50Ω (isolated) *
- M = 1-5V across 250Ω (isolated) *
- X = None

*Enhanced or Tricolor only.
Isolated requires AC power

POWER:

- 1 = 120V AC 50/60Hz
- 2 = 240V AC 50/60Hz
- 4 = 12V DC
- 7 = 24V DC
- 8 = 28V DC
- 9 = 48V DC
- 0 = 125V DC
- 6 = 250VDC
- U = 120V AC / 125V DC

INPUT LEVEL:

- 12 = Single phase two wire 1 element
- 13 = Single phase three wire 2 element
- 33 = Three phase three wire 2 element
- 34 = Three phase four wire 2½ element
- 3E = Three phase four wire 3 element

EXAMPLE:

4	B	4	N	1	H	3	3	1	F	A	P	T	Y	X
---	---	---	---	---	---	---	---	---	---	---	---	---	---	---

(4) BG-241, (B) zero at bottom, (4) 4-1/2 digit Standard display, (N) Hi/Lo setpoint, (1) 1% of F.S. setpoint hysteresis, (H) Watts, poly phase, (33) Three phase three wire, (1) 120 VAC 50/60 Hz power, (F) 4-20 mADC isolated retransmit, (A) RS232 communication, (P) peak/valley hold, (T) trend indicator, (Y) spray tight face, (X) red LED color

**On Standard & Enhanced, bar color matches digit color unless specified on order

Options and features vary by model. Contact factory for details and latest specifications.

 **WESCHLER INSTRUMENTS**
DIVISION OF HUGHES CORPORATION
16900 FOLTZ PARKWAY - CLEVELAND, OH 44149
Phone: (440) 238-2550 - Fax: (440) 238-0660
www.weschler.com e-mail: sales@weschler.com

DIMENSIONS

BG-241

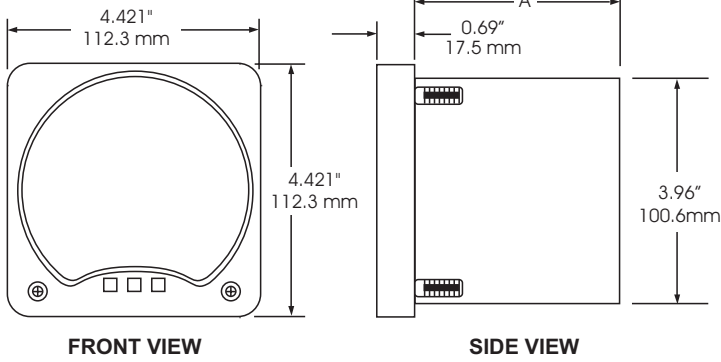

BG-261

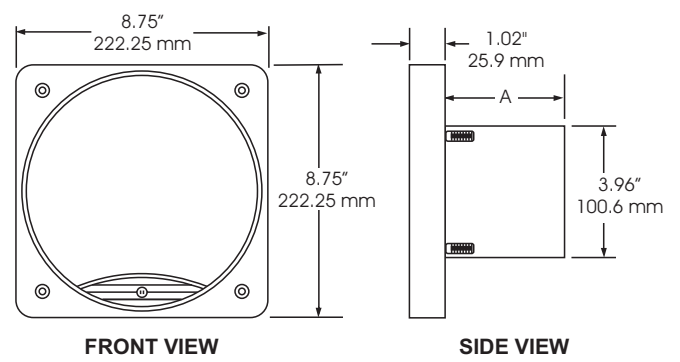

A = 5.15" (130.8mm). Add 0.6" (15mm) for screw terminals or 0.85" (22mm) for studs on analog backplate

BG-251 / 281

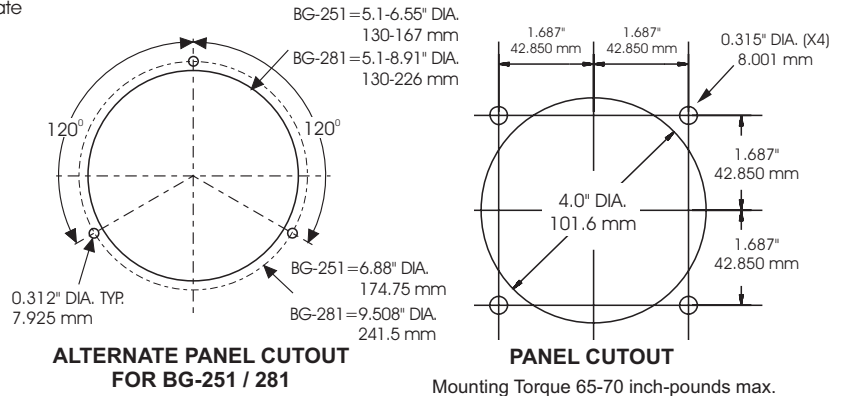
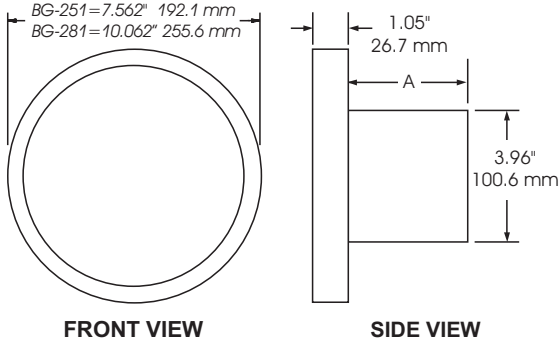

TERMINAL CONNECTIONS

