

# BG TC Series Circular TriColor BarGraphs™

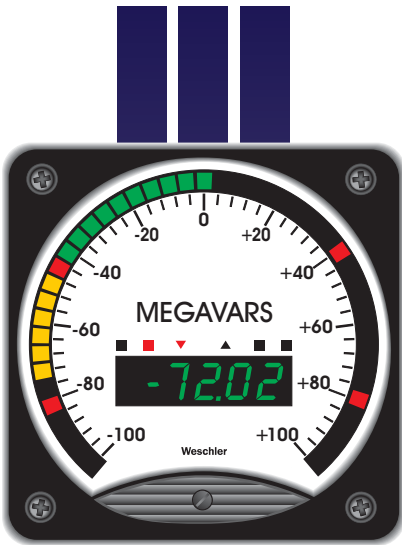

BG-261TC  
Center Zero

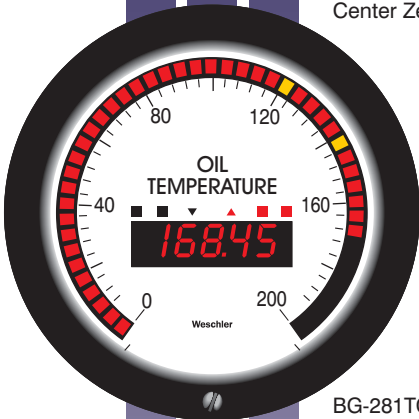

BG-281TC  
Solid Bar  
Mode

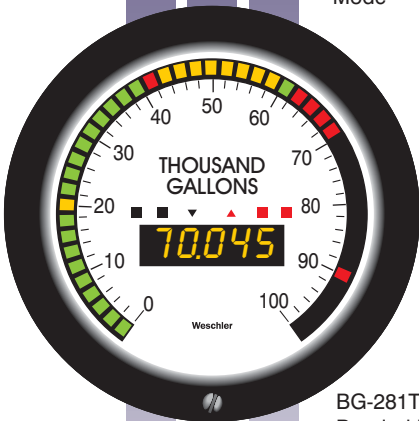

BG-281TC  
Banded Bar  
Mode

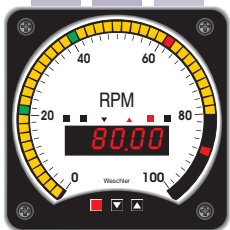

BG-241TC

The Weschler Instruments BG "TC", TriColor BarGraphs provide the quickest way to spot problems in your process control panels with bright changing colors. Each 50 segment LED (Light emitting diode) of the BG TC family has the ability to illuminate as Red (Danger), Yellow (Caution), or Green (Safe condition). The bar color identification can be changed by the user, from the front pushbuttons or through a tamper safe mode.

The Weschler BG Series Circular BarGraphs consist of model 241, 261 and 281. The panel footprint, shape and mounting meets direct retrofit applications for 4½" and 8¾" switchboard meters, as well as 8" pressure gauge meters. The electronics housing remains the same. Quick identification of trouble conditions can help prevent equipment damage or production loss, thus reducing down time and maintenance costs, and improving operational safety. The fully programmable Weschler BG TC BarGraph™ fits the widest range of inputs and retrofits most edgewise switchboard and panel meters. Weschler's instruments satisfy the high quality standards set forth by the utility, OEM, and process control industries.

## FEATURES

**Large, high resolution 50 segment LED bar array**

**5 digit display with resolution to 0.01%**

**Field programmable functions**

- Zero and full scale point location
- Setpoint type (Hi or Low)
- Hysteresis & latching
- Setpoint time delay
- 16 step dimming
- Digital display for engineering units
- Enable/disable front buttons
- I.D. selection for communication
- Bar form
- Peak / Valley enable
- Color zones
- Over-range/Under-range flashing
- Lamp test

**Form-C relay outputs**

- Normally Open
  - 5A, resistive @ 250V AC
  - 5A, resistive @ 28V DC
- Normally Closed
  - 3A, resistive @ 250V AC
  - 2A, resistive @ 28V DC

**Peak and Valley hold**

**Trend indication for signal direction**

**Communication**

RS232/485, SCADA, DCS

**Analog retransmit**

4-20, 0-1mA DC  
1-5, 0-1, 0-5 V DC

**Retrofit sizes for:**

GE/Yokogawa AB/DB 40, 4½" and AB/DB 16 8¾" switchboard meters

Crompton 075/07, 4½" and 8¾" switchboard meters

Ashcroft, Heise 8" gauges

Dixson BW051/P

Weschler K241, K261

**Versatile selection of inputs**

DC	Up to 5A & 250V
AC	Up to 5A & 250V
Thermocouple	J, K, T
RTD	10Ω Cu or 100Ω Pt
Serial	ASCII
Frequency	Line or mag pickup
Process Control	V, mA



**WESCHLER INSTRUMENTS**  
DIVISION OF HUGHES CORPORATION

16900 FOLTZ PARKWAY - CLEVELAND, OH 44149  
Phone: (440) 238-2550 - Fax: (440) 238-0660  
www.weschler.com e-mail: sales@weschler.com

# SPECIFICATIONS

## Bar Display

50 segment LED  
 2% full scale resolution  
 Circular display:  
 BG-241 285°  
 BG-261/281 255°

## Digital Display

5 digit -9999 to 99999  
 Resolution 0.01% full scale  
 Linearity ±1 count

Height  
 BG-241 0.4" (10.16mm)  
 BG-261/281 0.8" (20.32mm)

## Response Time

DC <600msec full scale  
 AC <800msec full scale

## Temperature

Operation 0° to 50°C, <95% RH  
 (non-condensing)  
 Storage -40° to 85°C

## Input Isolation

AC Transformer isolated  
 (>50mA, 1V)  
 DC Differential

## Sensor Power

24VDC (excitation power) @ 90mA DC

## Setpoints

Up to 4 SPDT relays with form C  
 contacts available  
 Hysteresis 0.00-10.00% FS or latching  
 Time delay 0-10 sec.

## Retransmit Signals

4-20mA DC  
 0-1mA DC  
 1-5V DC  
 0-5V DC

## Communication

RS232  
 RS485 (2-wire)

## Power

120, 240V AC (13VA)  
 12, 24, 28, 48, 125, 250V DC (8W)

## Input Impedance

2Mohm @ >4V DC  
 30kohm @ 120V AC P.T.  
 0.1ohm @ 5A AC C.T.  
 250ohm @ 4-20mA DC  
 100ohm @ 10-50mA DC

## Input Overload Ratings

200%, not to exceed 10A  
 200%, not to exceed 300V

## Input Sensitivities [ANSI C39.1]

DC:  
 Current 50 microamp - 5A  
 Voltage 50mV - 250V  
 Accuracy 0.04% of full scale  
 ± 1 count

AC RMS:  
 Current 1mA - 5A  
 Voltage 50mV - 250V  
 Accuracy 0.1% of full scale ± 1 count

## Temperature:

Thermocouple °C °F  
 Type J -210 to 795 -346 to 1463  
 Type K -270 to 851 -454 to 1563  
 Type T -270 to 400 -454 to 752

Accuracy 0.1% of full scale ± 1 count  
 Linearity 50 point, 0.1%

RTD °C °F  
 100Ω Pt -260 to 700 -436 to 1292  
 Alpha 0.00385 & °C standard  
 Other Alpha ratings available  
 10Ω Cu -100 to 260 -148 to 500

Accuracy 0.2% of full scale ± 1 count

## Frequency:

50Hz to 20kHz at 5 to 250V p-p  
 Accuracy 0.1% of full scale ± 1 count

## Line Frequency (55 to 65 Hz):

Accuracy 0.01% of full scale  
 ± 1 count

# ARTWORK GUIDELINES

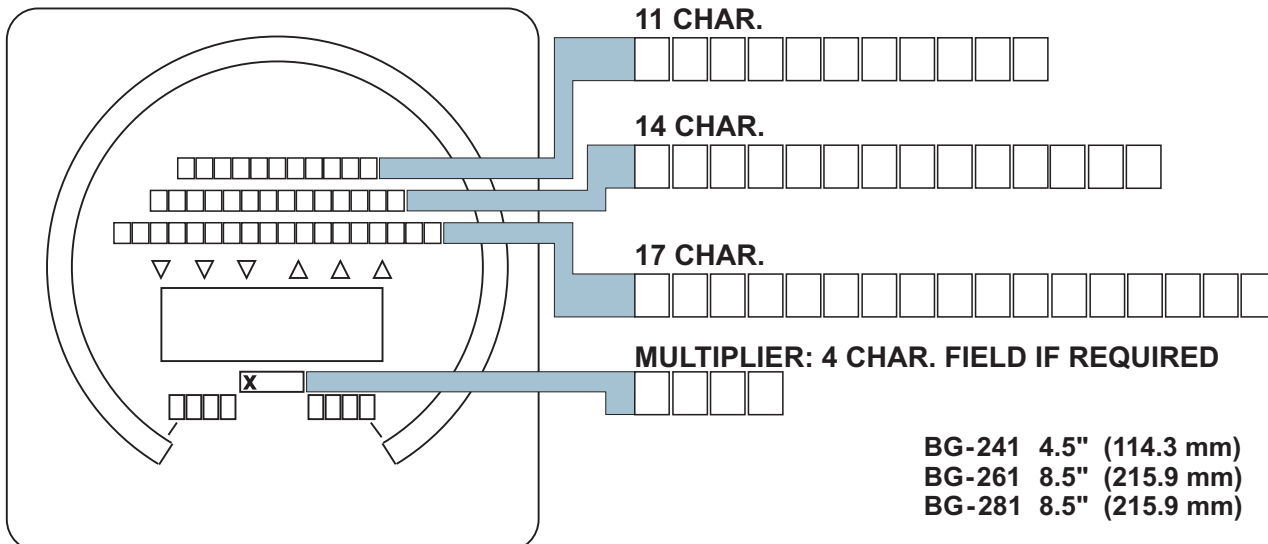



# DIMENSIONS

## BG-241TC

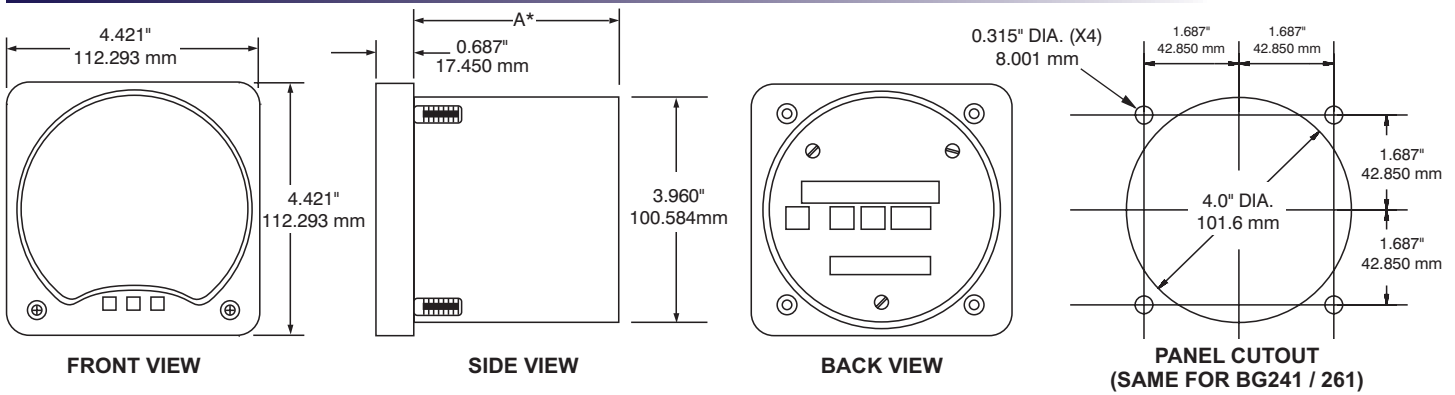

## BG-261TC

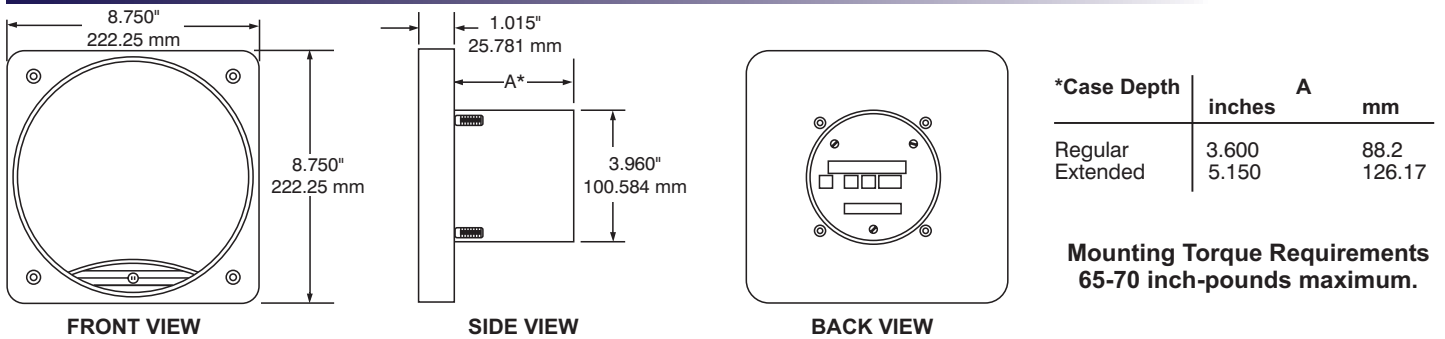

## BG-281TC

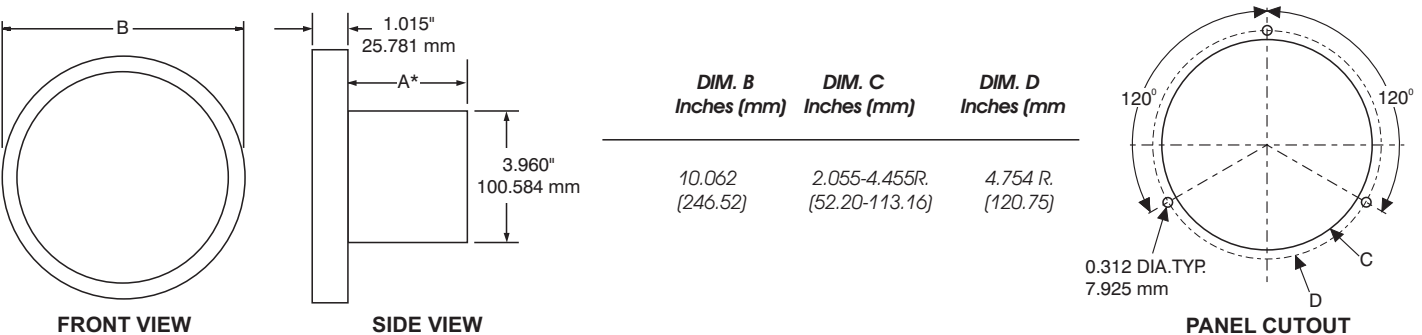

# TERMINAL CONNECTIONS

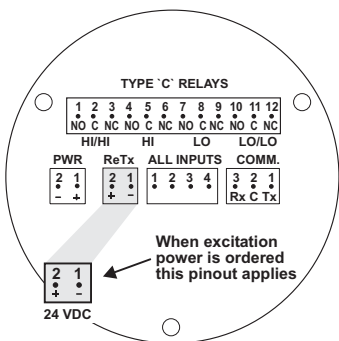

### INPUTS

#### VOLTAGE / CURRENT

(1) Hot Side (+) (2) Return Side (-)

#### RTD

(1) + Source (2) + Sense  
(3) - Sense (4) - Source

#### MAGNETIC PICKUP

(1) - (2) +

#### THERMOCOUPLE

Provided w / flying lead and plug  
AC LINE FREQUENCY

(1) Hot Side (+) (2) Return Side (-)

**AC Inputs have 6/32 barrier lug connections.**

#### POWER

(1) Hot Side (+) (2) Return Side (-)

#### EXCITATION POWER 24 VDC

(1) - (2) +

#### COMMUNICATIONS

(1) Transmit (2) Common  
(3) Receive

### RELAY CONTACTS\*

(1) AL 1 N.O. (2) AL 1 C.  
(3) AL 1 N.C. (4) AL 2 N.O.  
(5) AL 2 C. (6) AL 2 N.C.  
(7) AL 3 N.O. (8) AL 3 C.  
(9) AL 3 N.C. (10) AL 4 N.O.  
(11) AL 4 C. (12) AL 4 N.C.

\* N.O. = Normally Open  
N.C. = Normally Closed  
C. = Common

BG-241TC / BG-251TC / BG-261TC / BG-281TC

Options and features vary by model. Contact factory for details and latest specifications. For AC power measurements see the terminal connections & wiring diagrams on the BG-AC Power Circular BarGaphs.



16900 FOLTZ PARKWAY - CLEVELAND, OH 44149  
Phone: (440) 238-2550 - Fax: (440) 238-0660  
www.weschler.com e-mail: sales@weschler.com

6/1/10